

ASSEMBLAGGIO TELAIO

SOLUZIONE "B" - CON SOPRALUCE

PORTE BLINDATE S.R.L.
SEDE LEGALE E AMMINISTRATIVA: VIA EINAUDI, 2 (Z.I.)
STABILIMENTO: VIA TONIOLO, 13/A (Z.I.) - 61032 FANO (PU) - ITALIA
TEL. +39.0721.81.91 R.A.
FAX +39.0721.85.54.60 - FAX +39.0721.854038 (UFF. TECNICO)
INTERNET: www.dibigroup.com
MAIL: info@dibiporteblindate.it MAIL: info@dibigroup.com

dibi

1 Aprire l'imballo del TELAIO e controllare il contenuto.

- B1** - MONTANTE TELAIO SERRATURA
- B2** - TRAVERSA SUPERIORE
- B3** - MONTANTE LATO CERNIERA
- B4** - TRAVERSA SOPRALUCE
- B5** - BARRA FILETTATA CON VITI PER SERRAGGIO TRAVERSA
- B6** - GUARNIZIONE VETRO ESTERNA ADESIVA
- B7** - VETRO SOPRALUCE
- B8** - DISTANZIATORI DI CENTRAGGIO VETRO
- B9** - VITI CON BOCCOLE PER FISSAGGIO CORNICI FERMA VETRO
- B10** - CORNICI FERMA VETRO
- B11** - GUARNIZIONE VETRO INTERNA A INCASTRO

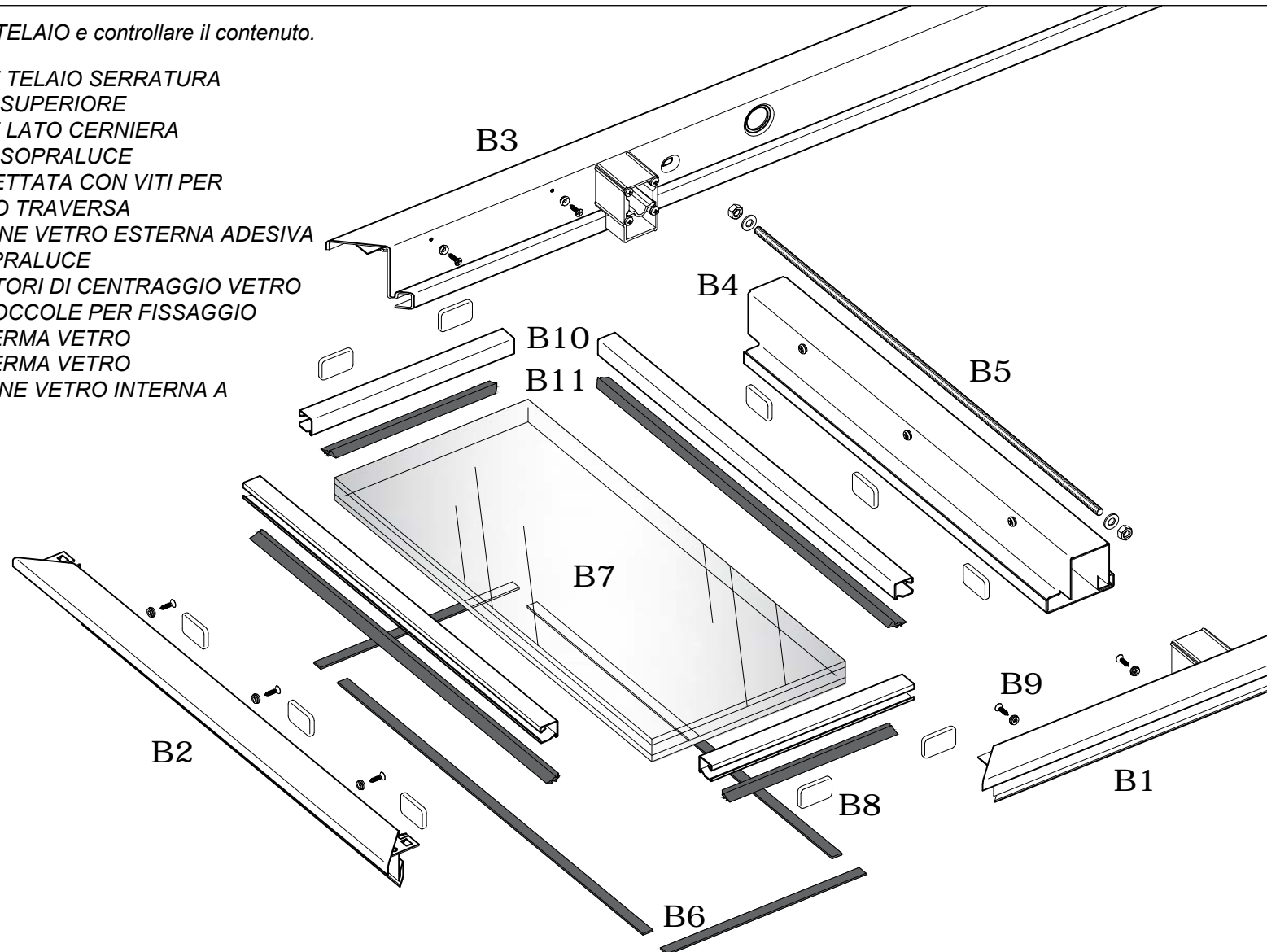

NOTA! Vedi Foglio «ASSEMBLAGGIO TELAIO SOLUZIONE "A" » fase 1 per il resto dei componenti del telaio standard.

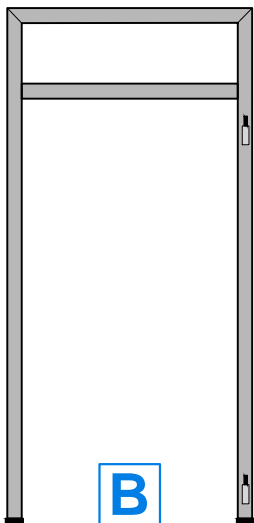

B

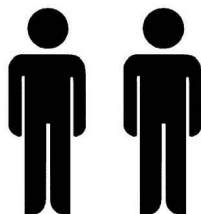

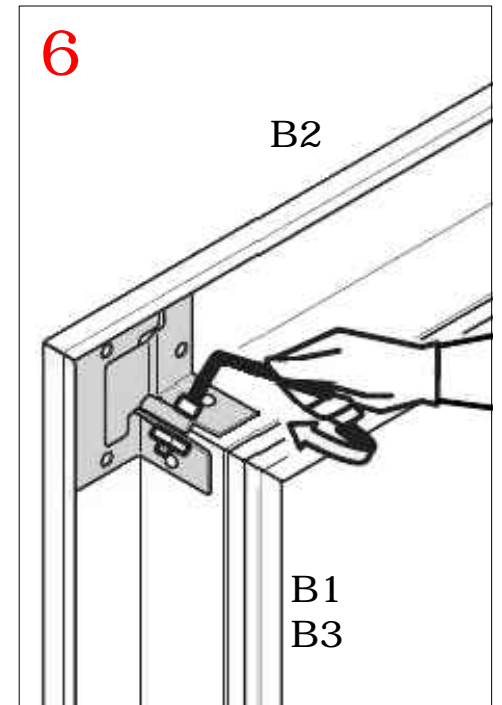
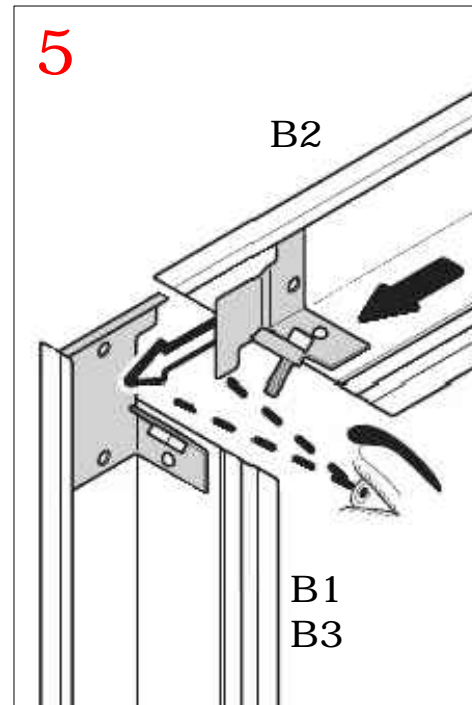
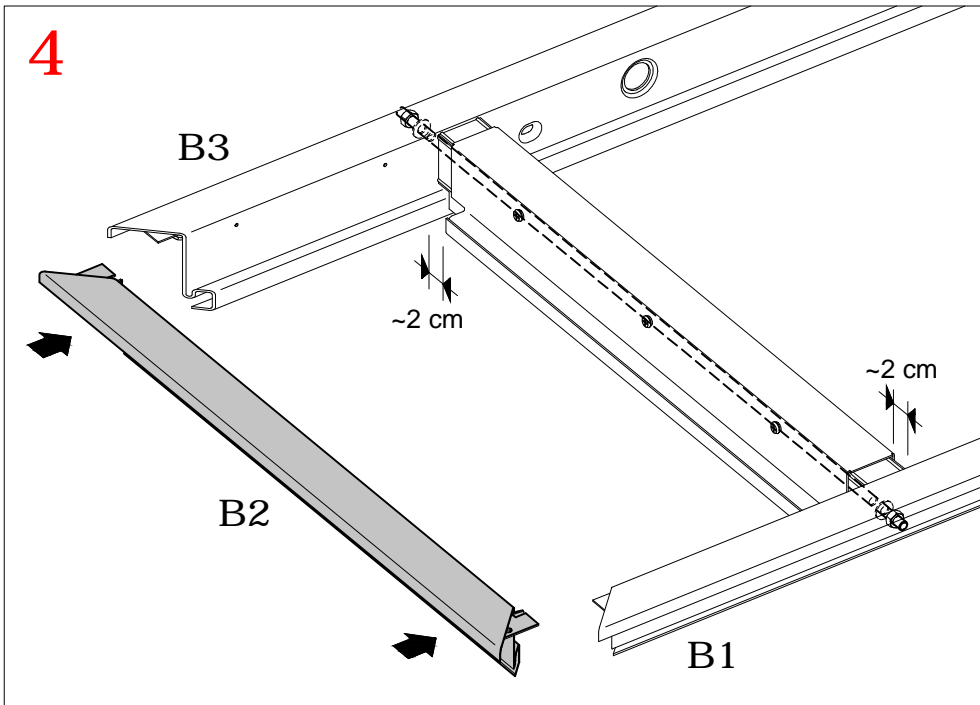
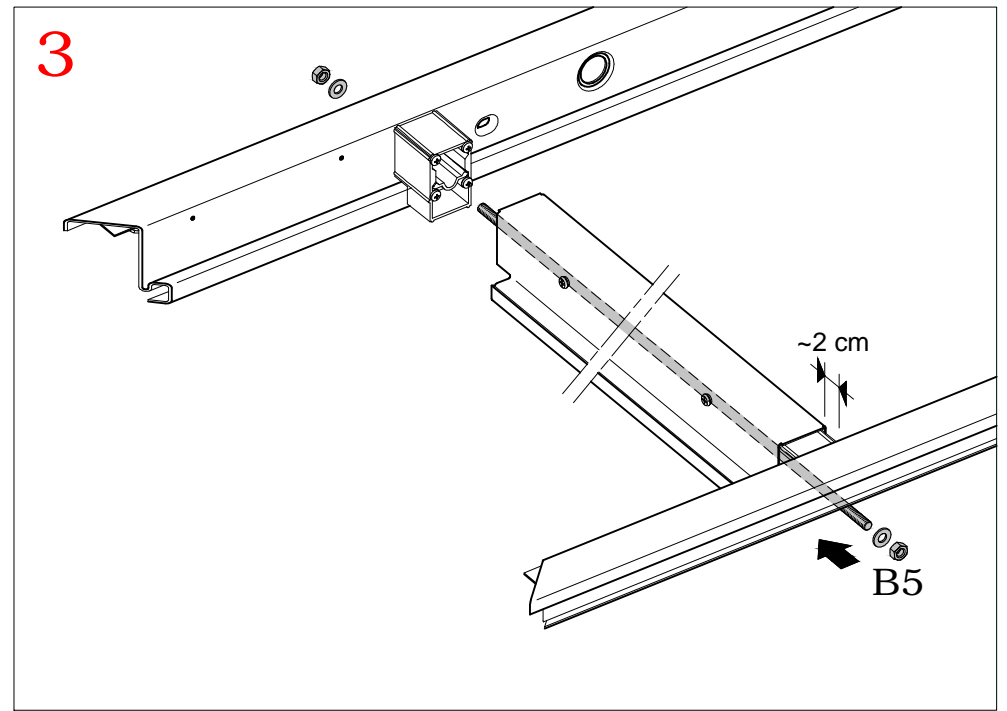
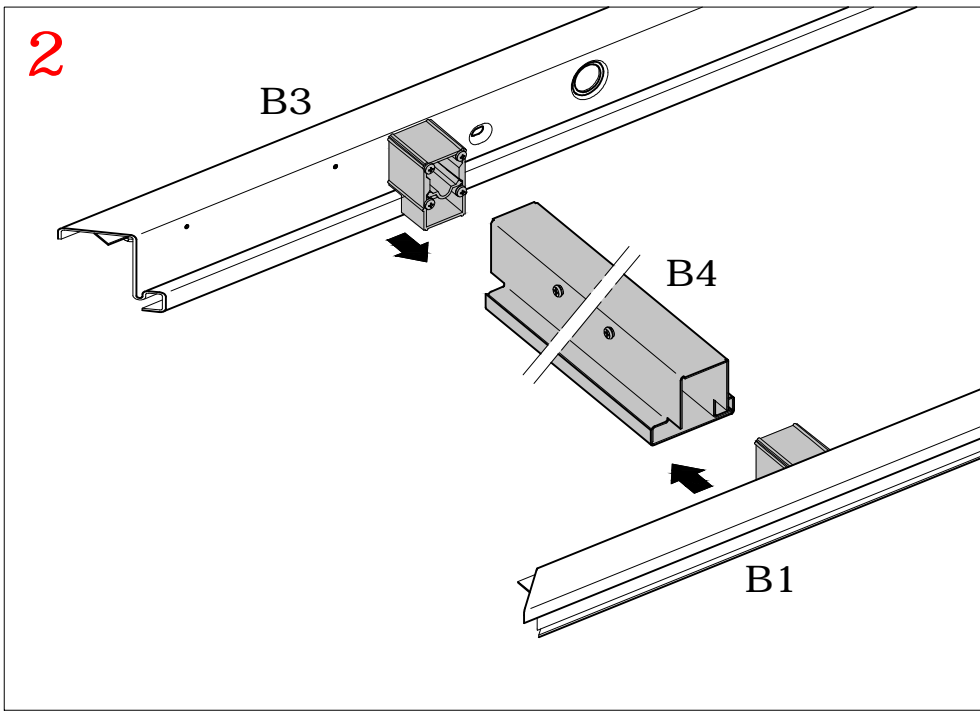

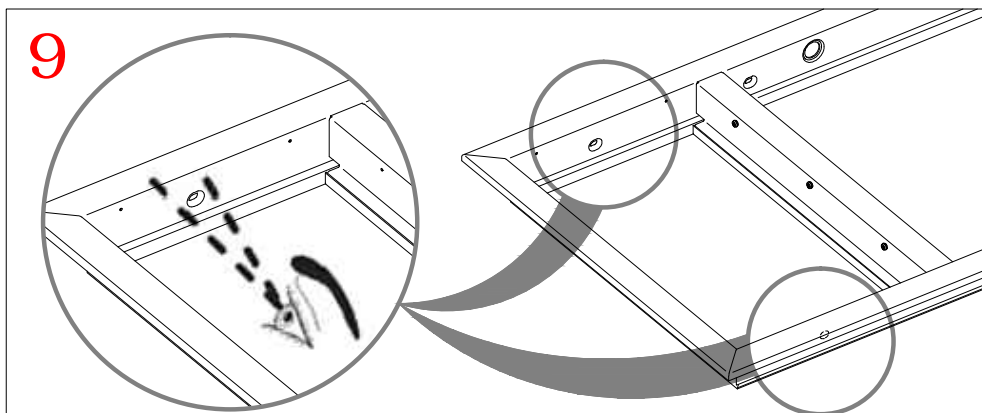
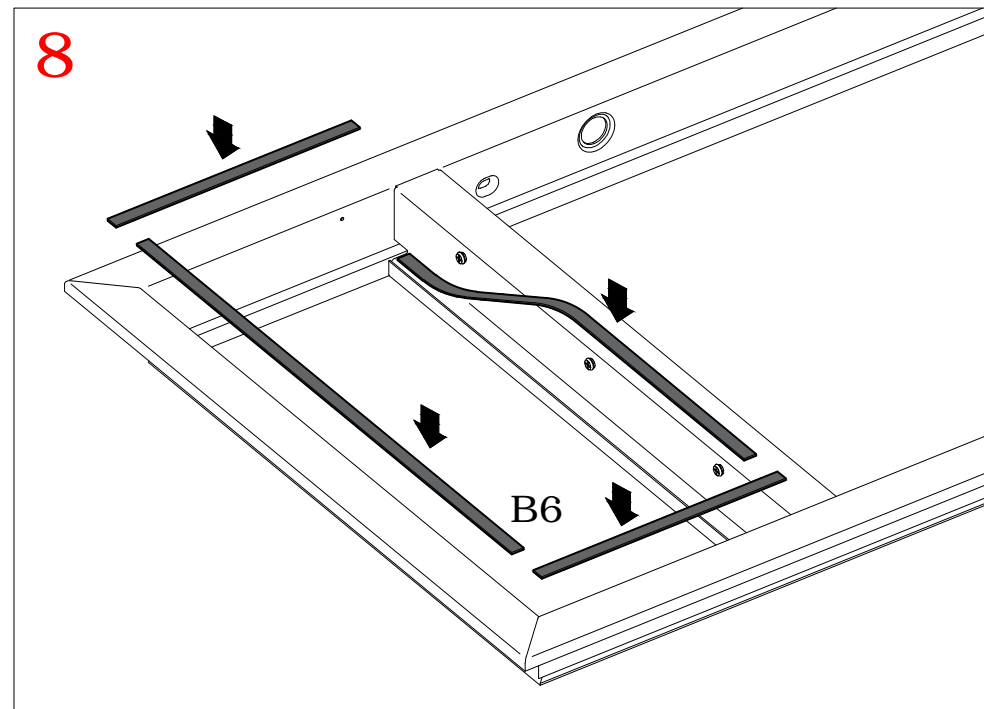
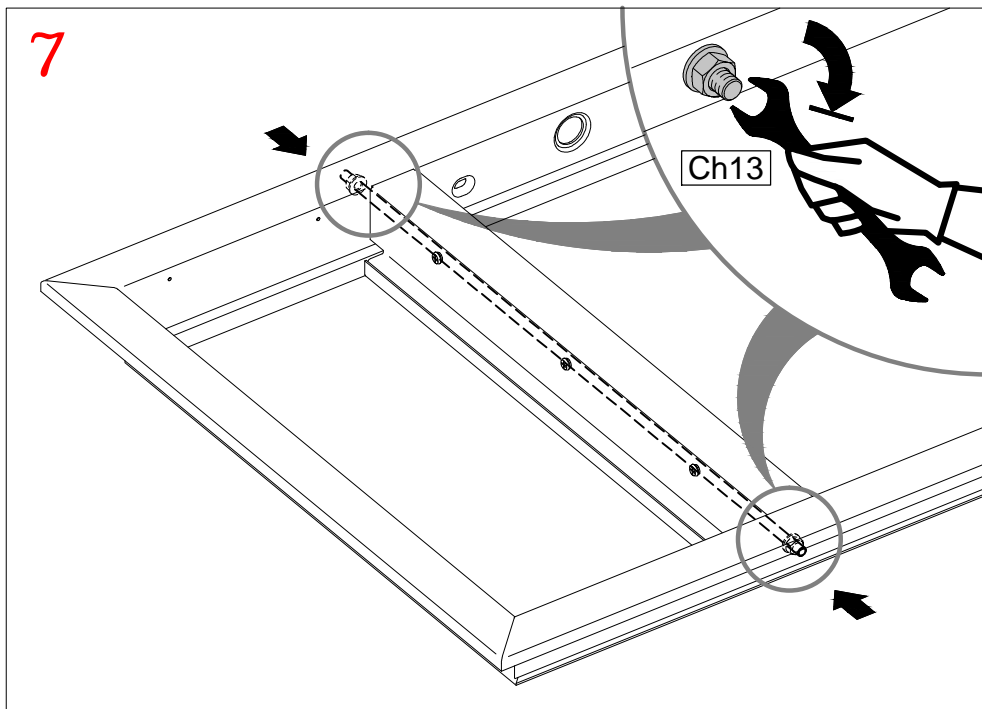

NOTA! PRIMA DI MONTARE IL VETRO VERIFICARE CHE LA ZONA DEI MONTANTI TRA LE DUE TRAVERSE NON CONTENGA I FORI DI FISSAGGIO AL CONTROTELAIO. ALTRIMENTI PROCEDERE PRIMA AL POSIZIONAMENTO DEL TELAIO SUL CONTROTELAIO. VEDERE FASI 4...9 DEL FOGLIO «ASSEMBLAGGIO TELAIO SOLUZIONE "A" »

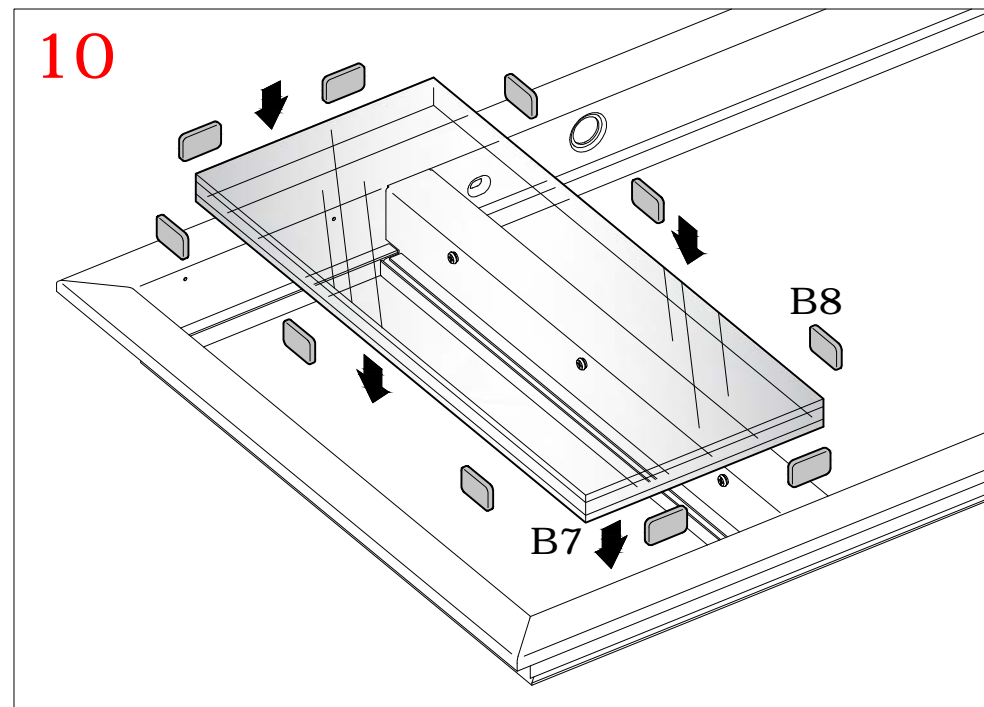

11

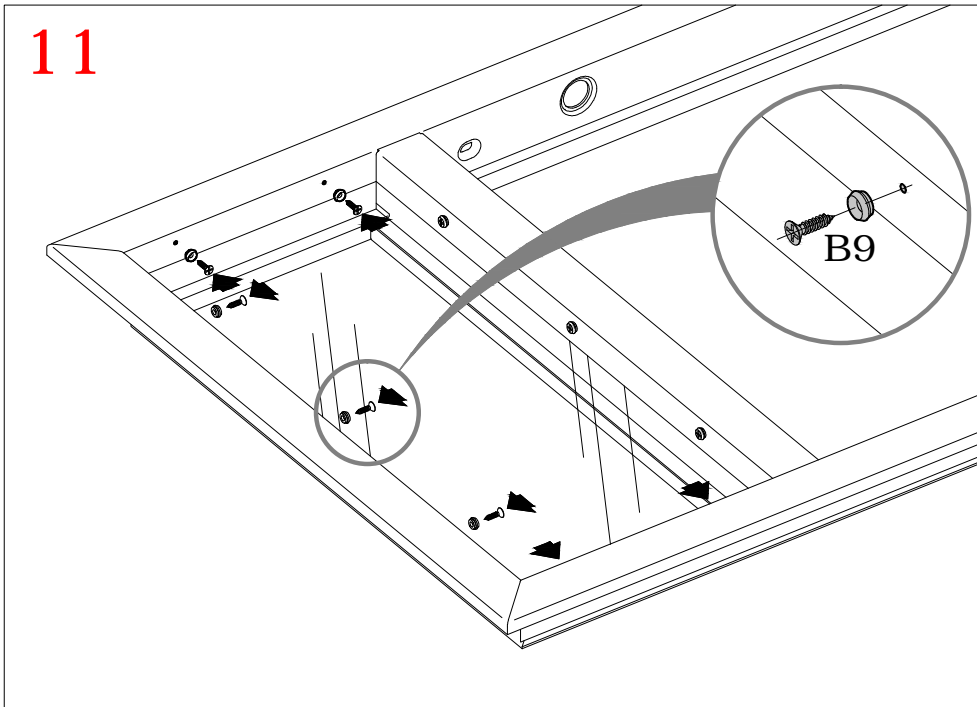

12

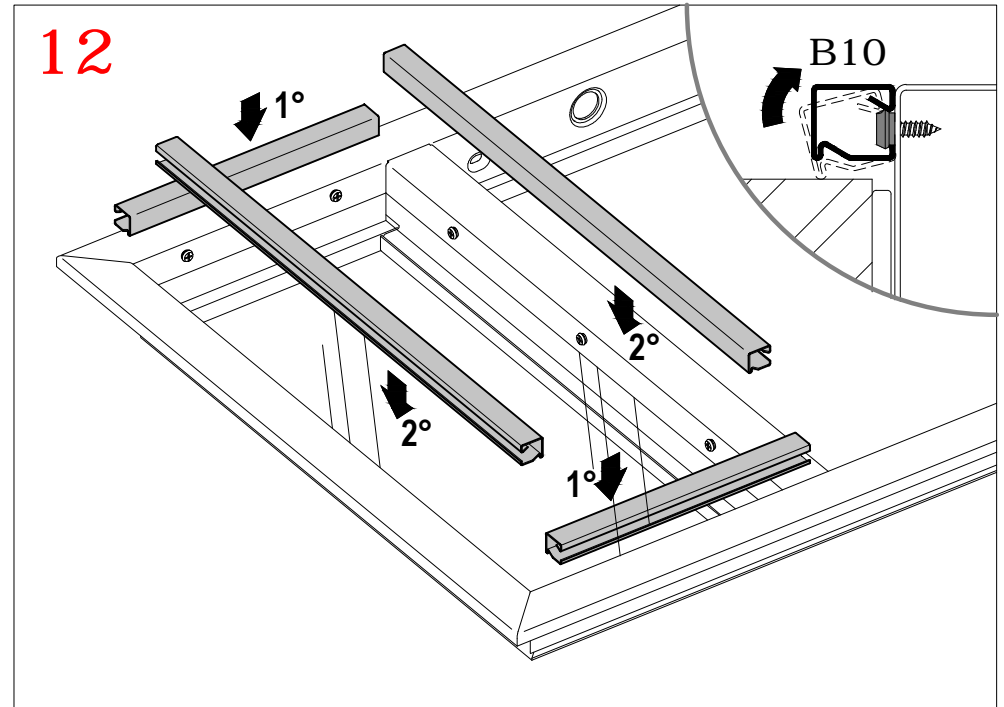

13

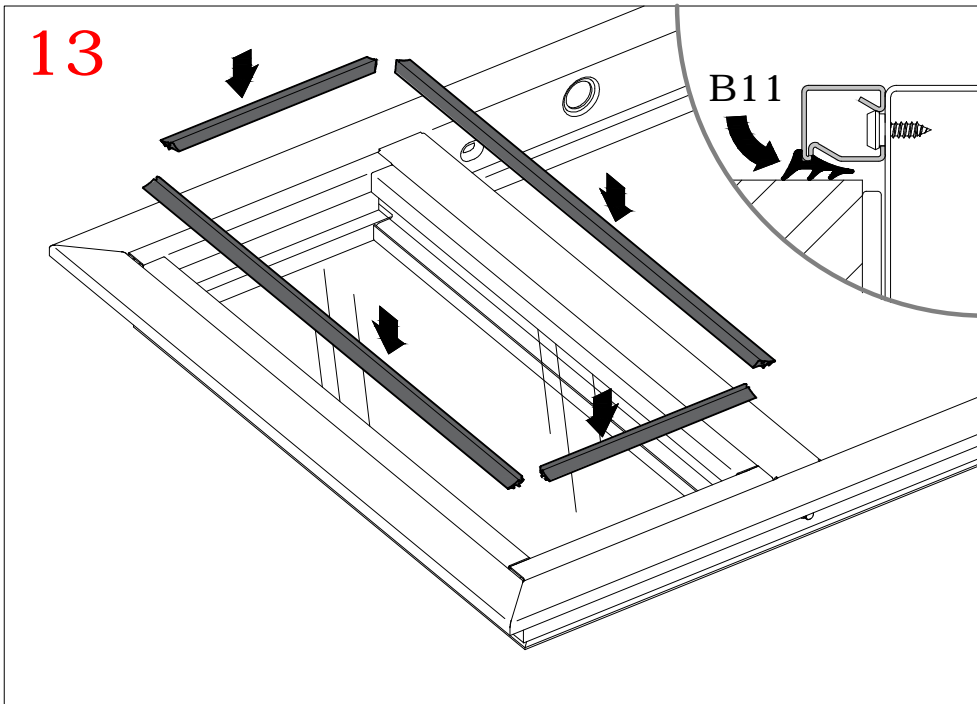

NOTA! PER TERMINARE LA PREPARAZIONE ED IL POSIZIONAMENTO DEL TELAIO SUL CONTROTELAIO VEDERE FASI 4...9 DEL FOGLIO «ASSEMBLAGGIO TELAIO SOLUZIONE "A" »

